

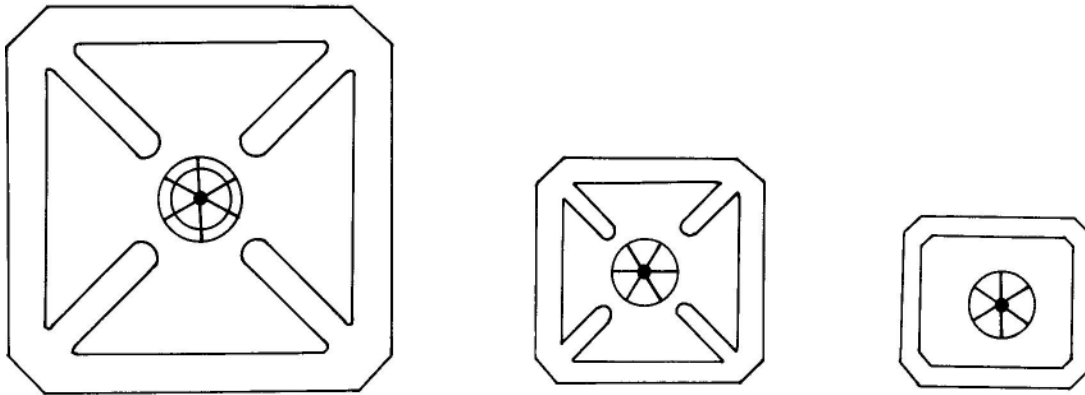

## WASHERS, CAPS & NUTS

### SELF-LOCKING WASHERS (SQUARE)



Sizes	2 1/2 x 2 1/2	1 1/2 x 1 1/2	1 1/4 x 1 1/8
Thickness	.015 min.	.015 min.	.015 min.
Material	Mild Steel	Mild Steel	Mild Steel
Plating	Galv.	Galv.	Galv.
Other materials available	Alum., S.S.	Alum., S.S.	Alum., S.S.
Packed per carton	1000	3000	1000, 5000
Shipping weight per 1000	28 1/2 lbs.	10 lbs.	6 lbs.

**CONTINENTAL** Self-Locking Washers are used in conjunction with **CONTINENTAL** weldpins®, insul anchors and lacing anchors to fasten insulation in place. Simply press the self-locking washers onto the pin up against the insulation until the desired position is reached and then clip off, or bend over, the remaining portion of pin for a permanent attachment.

The choice between Round or Square self-locking washers is basically a matter of aesthetics or personal preference. The domed, multi-lanced hole design provides for ease of locating washer on weldpin® and positive self-locking. Some styles of washers are manufactured with a beveled edge to prevent the washer from cutting into the insulation facing.

**CONTINENTAL** Self-Locking Washers are available according to the chart above and with standard 10 GA, or 12 GA hole sizes off-the-shelf. Other material/plating combinations and hole sizes are available by special order.

**TO ORDER OR SPECIFY GIVE:**

1. Diameter of Pin/Stud on which washer is to be used.
2. Size of washer
3. Material

**All information contained herein is subject to change without notice.  
For more information-consult your nearby Continental Field sales representative.**