

Permacote® Linacoustic® Standard/HP
Fiber Glass Duct Liners

Description

Permacote Linacoustic Standard and HP are flexible duct liner insulations made from strong, glass fibers bonded with a thermosetting resin. The airstream surface is protected with Permacote®, a state-of-the-art acrylic surface coating system.

Factory-Applied Edge Coating*

Edge coating is factory applied to the edges of the liner core, assuring coverage of the leading edges per NAIMA/SMACNA requirements. Shop fabrication cuts may be coated with the SuperSeal® Duct Butter and Edge Treatment products (refer to publication AHS-202).

Uses

Permacote Linacoustic Standard and HP are specifically designed for lining sheet metal ducts in air conditioning, heating and ventilating systems. The exclusive Permacote II coating system offers exceptional durability in exposure to air velocity, as well as superior acoustical and thermal performance in systems operating at velocities up to 6,000 fpm (30.5 m/sec) and operating temperatures up to 250°F (121°C).

Permacote Linacoustic HP offers more performance per inch of thickness than other liners, making it a clear choice for special performance specifications.

Advantages

Improves Indoor Building Environment. Permacote Linacoustic improves indoor environmental quality by helping to control both temperature and sound.

Withstands High Velocity. Permacote Linacoustic products have been tested to the recommended maximum velocity of 6,000 fpm (30.5 m/sec). Fiber erosion test results were determined using the Isokinetic Sampling Method described in JM Fiber Erosion Testing Fact Sheet HSE-133FS.

Absorbs Disturbing Sound. Permacote Linacoustic has exceptional sound-absorbing properties far exceeding the requirements of ASTM C 1071. Duct-transmitted noise, such as crosstalk and sound energy from air movement and mechanical equipment is noticeably reduced.

Conserves Energy. The unique glass fiberization process used in the manufacture of Permacote Linacoustic provides very good thermal properties.

Resistant to Dust and Dirt. The tough, acrylic polymer Permacote coating helps guard against the incursion of dust or dirt into the substrate, minimizing the potential for biological growth.

Will Not Support Microbial Growth. Permacote coating is formulated with a protective agent to protect the coating against potential growth of fungus and bacteria. The protective agent is EPA registered for use in HVAC applications, and designed to last the life of the system.

Permacote Linacoustic duct liner meets all requirements of ASTM C 1071 for fungi and bacterial resistance. Tests were conducted in accordance with ASTM C 1338 and ASTM G 21 (fungi testing) and ASTM G 22 (bacteria resistance testing). Detailed information is available in Johns Manville fact sheet HSE-103FS.

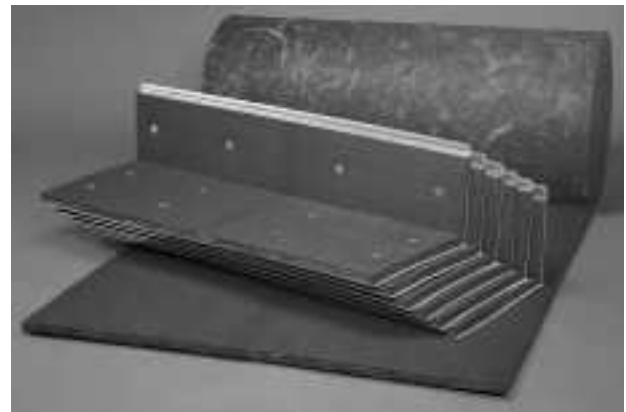

Operating Temperature Limit: 250°F (121°C)

Note: As with any type of surface, microbial growth may occur in accumulated duct system dirt, given certain conditions. This risk is minimized with proper design, filtration, maintenance and operation of the HVAC system.

Cleanability. If HVAC system cleaning is required, the Permacote airstream surface may be cleaned with industry-recognized dry methods. See the North American Insulation Manufacturers Association (NAIMA) "Cleaning Fibrous Glass Insulated Air Duct Systems."

Minimizes Pre-Installation Damage. The Permacote II coating system has more than twice the toughness of the original Permacote. It effectively doubles the resistance to damage that can occur from in-shop handling, fabrication, jobsite shipping, and installation.

Increased Resistance to Water. The Permacote airstream coating resists penetration of incidental water into the fiber glass wool core.

Easy to Fabricate. Permacote Linacoustic is light in weight and easy to handle. Clean, even edges can be accurately cut with regular shop tools.

Available Forms

Permacote Linacoustic Standard			Permacote Linacoustic HP	
Thickness	(in)	(mm)	(in)	(mm)
	1/2	13	1	25
	1	25		
	1 1/2	38		
	2	51		
Roll Width*	(in)	(mm)	(in)	(mm)
	34 to 36	864 to 914	34 to 36	864 to 914
	44 to 48	1118 to 1219	44 to 48	1118 to 1219
	56 to 60	1422 to 1524	56 to 60	1422 to 1524
	66 to 72	1676 to 1829	66 to 72	1676 to 1829
Roll Length**	(lineal feet)	(lineal meters)	(lineal feet)	(lineal meters)
	50	15	100	30.5
	100	31		
	150	46		
	200	61		

*Available in 1/4" (6.4 mm) increments. **Check with plant for availability.

Specification Data

Fiber Glass Duct Liners

Thermal Performance

Thickness (in)	Thickness (mm)	R-Value (hr•ft ² •°F)/Btu	R-Value m ² •°C/W	Conductance Btu/(hr•ft ² •°F)	Conductance W/m ² •°C
Permacote Linacoustic Standard					
1/2	13	2.2	0.38	.46	2.61
1	25	4.2	0.74	.24	1.36
1 1/2	38	6.3	1.11	.16	0.91
2	51	8.0	1.41	.13	0.74
Permacote Linacoustic HP					
1	25	4.3	0.77	.23	1.31

R-Value and Conductance are calculated from the material thermal conductivity tested in accordance with ASTM C 518 at 75°F (24°C) mean temperature.

Sound Absorption Coefficients (Type "A" Mounting)

Thickness (in)	Thickness (mm)	Sound Absorption Coefficient at Frequency (Cycles per Second) of						
		125	250	500	1000	2000	4000	NRC
Permacote Linacoustic Standard								
1/2	13	.03	.21	0.45	0.72	0.87	0.94	0.55
1	25	.09	.31	0.67	0.91	1.01	0.98	0.70
1 1/2	38	.21	.53	0.90	1.03	1.01	1.00	0.85
2	51	.20	.57	1.02	1.03	1.02	1.03	0.90
Permacote Linacoustic HP								
1	25	.04	.24	0.69	0.96	1.05	1.01	0.75

Coefficients were tested in accordance with Test Method ASTM C 423-90 and ASTM E 795.

ISO 9000 Certification

Johns Manville mechanical insulation products are designed, manufactured and tested in our own facilities, which are certified and registered to stringent ISO 9000 (ANSI/ASQC 90) series quality standards. This certification, along with regular, independent third-party auditing for compliance, is your assurance that Johns Manville products deliver consistent high quality.

Surface Burning Characteristics

Flame Spread not over 25
Smoke Developed not over 50

Per UL 723, ASTM E 84 and CAN/ULC S102-M88 test methods. If UL labels are required, they may be requested at time of order.

Specification Compliance

- ASTM C 1071, Type I, Flexible (Replaced HH-I-545B and NAIMA AHC 101)
- ASTM G 21 and G 22
- California Title 24
- SMACNA Application Standards for Duct Liners
- NAIMA Fibrous Glass Duct Liner Installation Standard
- NFPA 90A and 90B, FHC 25/50 and Limited Combustibility
- Conforms to ASHRAE 62-89
- NYC MEA 353-93-M
- State of Washington Building Services Department requirements for emissions of total volatile organic compounds (TVOC) and formaldehyde (CHOH) in accordance with ASTM D 5116-90
- Canada: CGSB 51-GP-11M
CAN/ULC S102-M88

Permacote Linacoustic Friction of Air in Straight Duct*

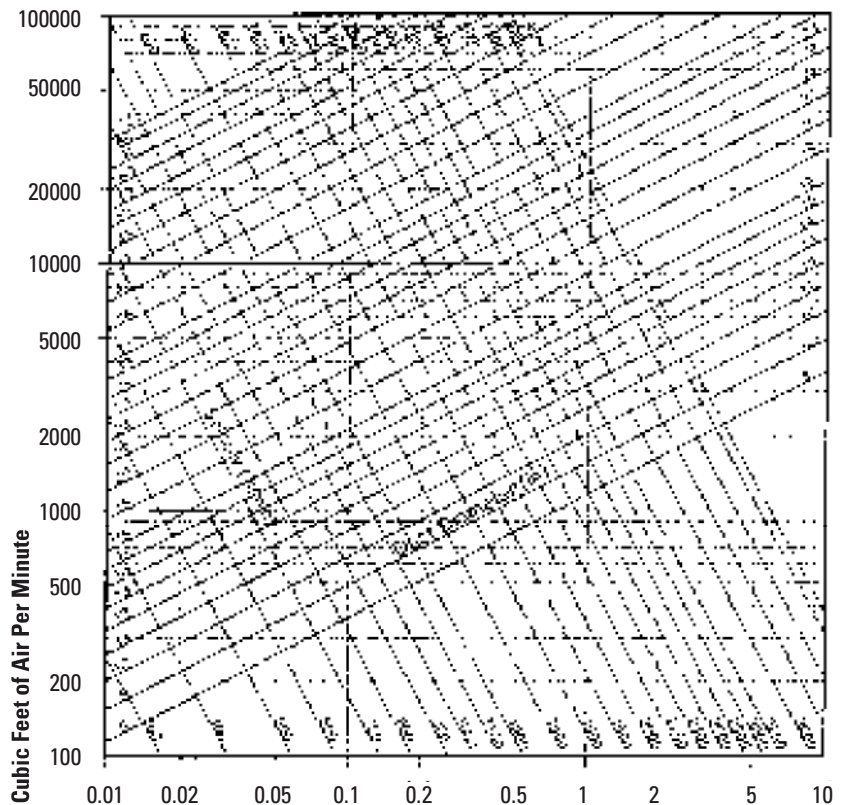

Friction Loss in Inches of Water Per 100 Feet

* Permacote Linacoustic Standard and HP Liner air flow properties were tested with the material applied to galvanized sheet metal duct with mechanical fasteners in accordance to the SMACNA "Duct Liner Application Standard".

Guide Specifications

Duct Lining (Coated)

Materials

Lining for Rectangular Metal Ducts. All ducts, where shown on the drawings, shall be lined with 1" (25 mm) thick Permacote Linacoustic fiber glass duct liner with factory-applied edge coating or approved equal. The liner shall meet the Life Safety Standards as established by NFPA 90A and 90B, FHC 25/50 and Limited Combustibility and the airstream surface coating should contain an immobilized, EPA-registered, anti-microbial agent so it will not support microbial growth as tested in accordance with ASTM G21 and G22. The duct liner shall conform to the requirements of ASTM C 1071, with an NRC not less than .70 as tested per ASTM C 423 using a Type "A" mounting, and a thermal conductivity no higher than .25 Btu•in/(hr•ft²•°F) at 75°F [.036 W/m•°C at 24°C] mean temperature.

Material Handling and Storage. Permacote Linacoustic shall be kept clean and dry during transportation, storage and installation. Care should be taken to protect the liner from exposure to the elements or damage from mechanical abuse.

Application

Installation Recommendations. All portions of duct designed to receive duct liner shall be completely covered with 1" (25 mm) thick Permacote Linacoustic. The smooth, black, acrylic-coated surfaces of the Permacote Linacoustic shall face the airstream. All Permacote Linacoustic shall be cut to assure tight, overlapped corner joints. The top pieces shall be supported by the side pieces.

Permacote Linacoustic shall be installed following the guidelines in the NAIMA "Duct Liner Installation Standard."

Permacote Linacoustic shall be adhered to the sheet metal with full coverage of an approved adhesive that conforms to ASTM C 916, and all exposed leading edges and transverse joints shall be coated with Permacote factory-applied or field-applied edge coating and shall be neatly butted without gaps. Shop or field cuts shall be liberally coated with Johns Manville SuperSeal[®] Edge Treatment or approved adhesive.

Metal nosings shall be securely installed over transversely-oriented liner edges facing the airstream at forward discharge and at any point where lined duct is preceded by unlined duct.

When velocity exceeds 4000 fpm (20.3 m/sec), use metal nosing on every leading edge. Nosing may be formed on duct or be channel or zee attached by screws, rivets or welds.

Permacote Linacoustic shall be additionally secured with mechanical fasteners spaced per the schedule shown in the diagram on the back page. The pin length should be such as to hold the material firmly in place with minimum compression of the material.



Restrictions and Limitations of Use

Fiber glass liner should not be used in the following applications:

- In air duct systems operating above 250°F (121°C)
- In systems conveying solids or corrosive gases
- Not closer to electric coils or gas heaters than indicated by equipment manufacturer
- In ducts operating at a velocity in excess of the liner's maximum recommended velocity
- Precautions should be taken to keep liner from coming in contact with liquid water when it is installed within the first six feet (1.83 m) downstream from a fresh air intake, outside grille, in-duct humidifier or other source of water
- In contact with water drain pan or dehumidification coils

Special Applications

Unconditioned Spaces. All ducts located outside of the building or in other unconditioned areas may require a higher thermal resistance to prevent condensation or energy waste. 1½" or 2" (38 mm or 51 mm) Permacote Linacoustic may be specified.

Metal ducts must be sealed to prevent moisture and dirt from entering the system.

Special Noise Control. In plenums or duct systems with severe noise conditions or more demanding acoustical requirements, use Permacote Linacoustic HP, or 2" (51 mm) Permacote Linacoustic.

Hospitals and Medical Facilities. Duct liner can be used without any special application or installation requirements in duct systems serving general areas of the hospital. Duct liners cannot be used in duct systems supplying surgical suites, delivery rooms, intensive care units and isolation areas as listed in the American Institute of Architects "Guidelines for Construction and Equipment of Hospitals and Medical Facilities," 1996-97 Edition.

Permacote® Linacoustic® Standard/HP

Fiber Glass Duct Liners

Duct Liner Installation

When velocity exceeds 4000 fpm (20.3 m/sec), use metal nosing on every leading edge. Nosing may be formed on duct or be channel or zee attached by screws, rivets or welds. A metal nosing shall also be installed at the fan discharge and at any point where lined duct is preceded by unlined duct.

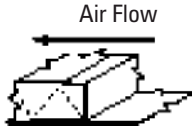

The velocity-rated side of liner must face the air flow

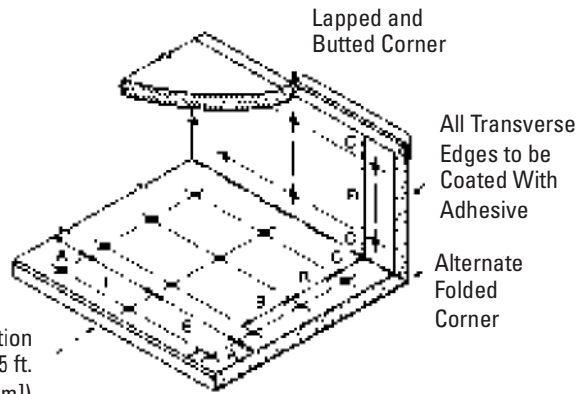

Duct Section
(Typically 4 ft. or 5 ft.
[1.22 m or 1.52 m])

Liner adhered to the duct with 90% min. area coverage of adhesive. Adhesive shall conform to ASTM C 916.

Shop or field cuts shall be liberally coated with SuperSeal® Edge Treatment or approved adhesive.

Maximum spacing for fasteners. Actual intervals are approximate.

Velocity*	Dimensions			
	A (in) (mm)	B (in) (mm)	C (in) (mm)	E (in) (mm)
0-2500 fpm (0-12.7 m/sec)	3 76	12 305	4 102	18 457
2501-6000 fpm (12.7-30.5 m/sec)	3 76	6 152	4 102	16 406

*Unless a lower level is set by the listing agency.

Liner Fasteners

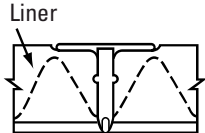

Type 1
Clinched Pin: Integral Head-Impact Applied

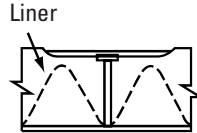

Type 2
Welded Pin: Integral Head

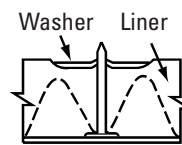

Type 3
Welded Pin: Press-On Head

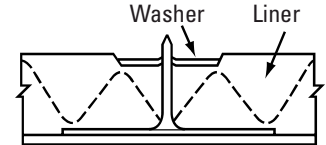

Type 4
Adhered Pin: Press-On Head

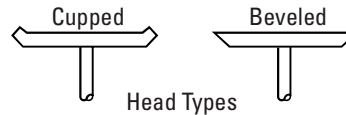

Head Types

Hold firmly in place with minimum compression of material

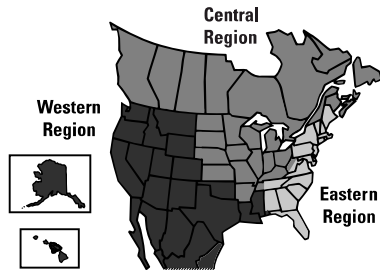

North American Sales Offices, Performance Materials Division

Eastern Region
P.O. Box 158
Defiance, OH 43512
(419) 784-7000
(800) 334-2399
Fax: (419) 784-7866

**Central Region,
Western Region**
P.O. Box 5108
Denver, CO 80217
(303) 978-2284
(800) 368-4431
Fax: (303) 978-4661

**Outside North
America**
(303) 978-4655
Fax: (303) 978-2627



Performance Materials Division
P.O. Box 5108
Denver, CO 80217-5108
Product Information: (800) 654-3103
www.jm.com

The physical and chemical properties of Permacote® Linacoustic® Standard and Permacote® Linacoustic® HP fiber glass duct liners represent typical, average values obtained in accordance with accepted test methods and are subject to normal manufacturing variations. They are supplied as a technical service and are subject to change without notice. Numerical flame spread and smoke developed ratings are not intended to reflect hazards presented by these or any other materials under actual fire conditions. Check with the Regional Sales Office nearest you to assure current information. **All Johns Manville products are sold subject to Johns Manville's Limited Warranty and Limitation of Remedy. For a copy of the Johns Manville Limited Warranty and Limitation of Remedy, call the 800 number below.** For information on other Johns Manville thermal insulations and systems and a copy of the Spec-Line® CSI formatted specifications, call (800) 654-3103. To access automated fax-on-demand service in the United States and Canada, simply call 1-888-INSULFX (1-888-467-8539) from a fax or phone.